



Quinta Strada

Design Sergio Bicego

Anno di produzione 1996

Production year 1996

Restyling 2015

[It] — Progettato nel 1996, il sistema di seduta Quinta Strada, è stato un progetto “pioniere” dello stile moderno. Rigoroso ma flessibile nella componibilità, viene ora rieditato attraverso un restyling attento ai dettagli del nuovo linguaggio contemporaneo. La finitura cromo nero del piede, l'assottigliamento delle staffe di congiunzione, la leggerezza della base e del supporto schienale sono gli eleganti particolari adeguati al moderno living. I diversi elementi della collezione Quinta Strada permettono numerose configurazioni, consentendo composizioni particolarmente interessanti anche nelle situazioni ad angolo.

Struttura

Base in multistrato e metallo, schienale in legno massello tamburato ricoperti in poliuretano espanso a quote differenziate (75IP e 30P) e rivestiti con velfodera accoppiata a fibra poliestere pressata 300 gr/mq.

Lo schienale è sostenuto da staffe in acciaio black nickel.

Piedini

In metallo con finitura black nickel.

Imbottitura

I cuscini seduta sono in poliuretano espanso a quote differenziate (35 IP – 35 IM – 25 IM) rivestiti con velfodera accoppiata a resinato 200 gr/mq. I cuscini schiena sono imbottiti con piuma d'oca lavata e sterilizzata mista a fibra di poliestere siliconata rivestita con tessuto di cotone 100% bianco.

[En] — Brought out in 1996, the Quinta Strada seating range was a pioneering design of the modern style. Streamlined yet modularly flexible, the range is now reproduced with a sensitive restyling that is mindful of the new contemporary language. The black chrome finish of the feet, the thinner joining clamps and the lightness of the base and back support are elegant touches appropriate to the modern lifestyle. The various pieces in the Quinta Strada collection allow for numerous configurations and particularly interesting compositions even in corner situations.

Structure

Base in plywood and metal, back in honeycomb-paneled solid wood padded with variable-density polyurethane foam (75 IP and 30 IP), covered with velfodera on a polyester fiber 300 gr/sqm. The back is supported by steel brackets black nickel.

Feet

Black nickel metal.

Padding

The seat cushions are in variable-density polyurethane foam (35 IP – 35 IM – 25 IM), covered in velfodera bonded with resin 200 gr/sqm. The back cushions are padded with washed and sterilized goose down quilted into sections mixed with silicon polyester fiber and covered with 100% white cotton fabric.

Divani / Sofas

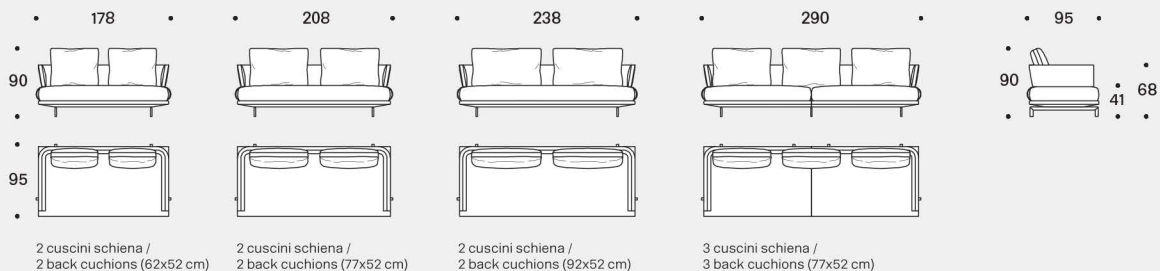

Laterali DX-SX / Right-left side units

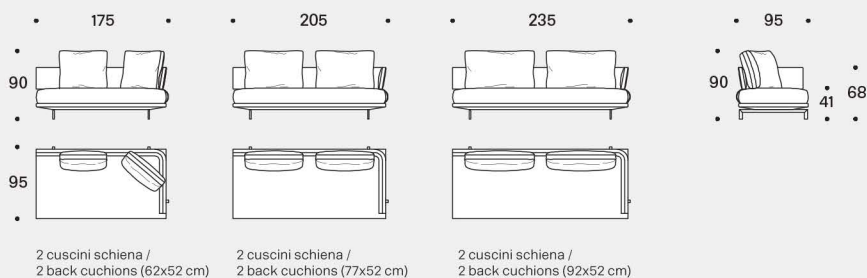

Terminali angolari DX-SX / Right-left corner end units

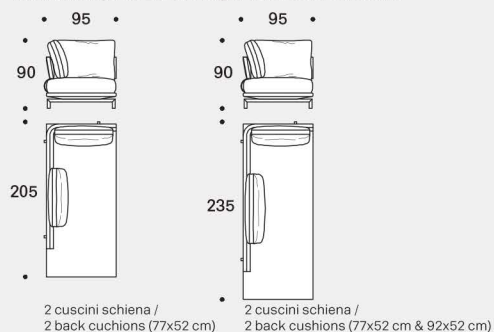

Penisola DX-SX / Right-left chaise longue

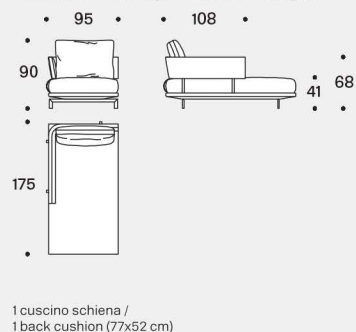

Pouf

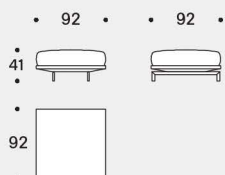

Cuscino poggiatesta / Lumbar cushion



Cuscini arredo / Throw cushions



Laterali DX-SX angolo 22,5° / Right-left 22,5° corner side units

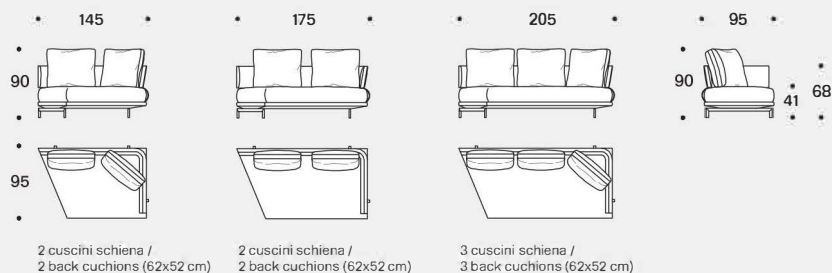

Terminali DX-SX angolo 22,5° / Right-left 22,5° corner end units

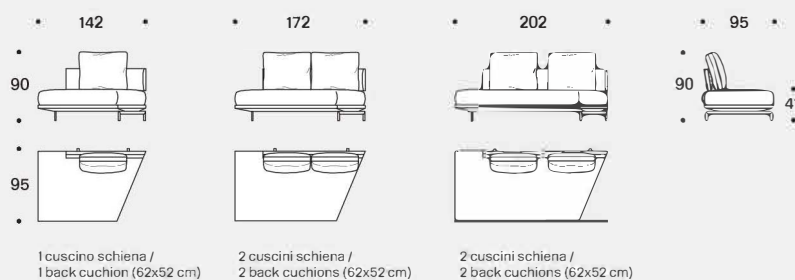

esempi di composizioni angolo 22,5° / Examples of 22,5° corner compositions

