

FRAME: Kiln dried hardwood timber
SEAT SUSPENSION: Warwick BlackCat webbing
SEAT CUSHION: suspension High resilience foam with 10 Year Guarantee
BACK CUSHION: Feather/fiber back cushion
LEG: Hardwood timber legs

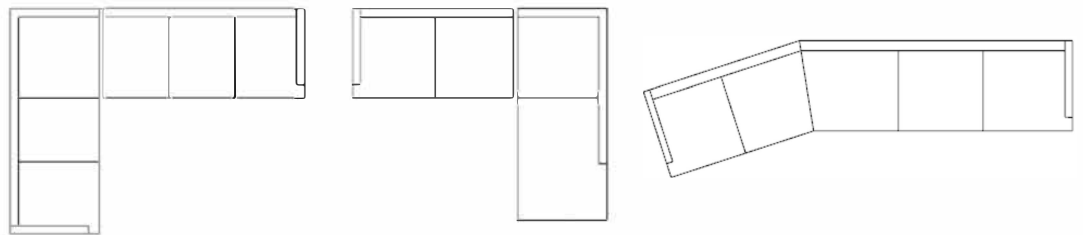



Modularexamples, see next page for modular components

FRAME:
SEAT SUSPENSION:
SEAT CUSHION:
BACK CUSHION:

Kiln dried hardwood Timber
Warwick Blackcat webbing suspension
High Resilience foam with 10 Year
guarantee Feather/fiber back cushions



Sofa with one arm:

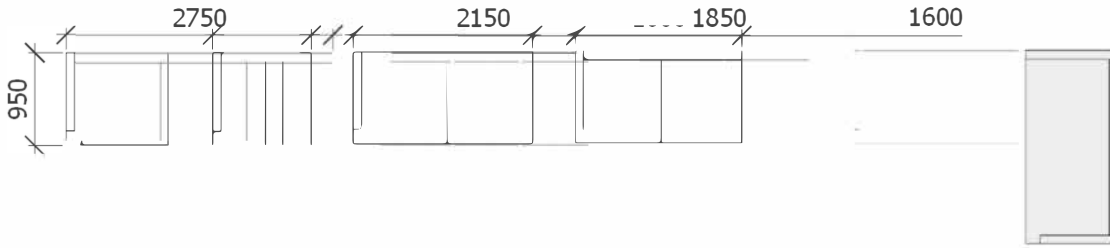

Sofa with corner return:

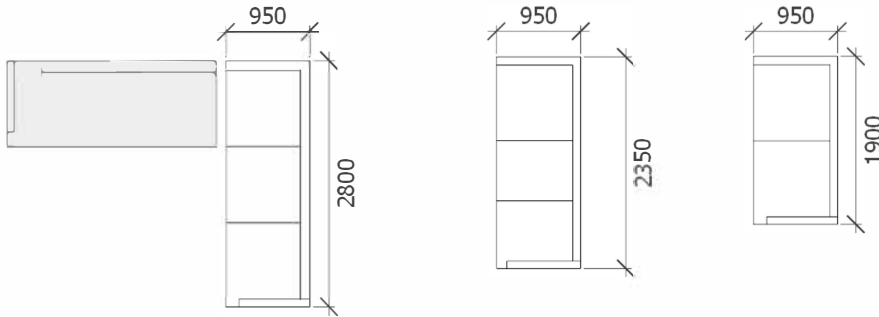

Chaise:

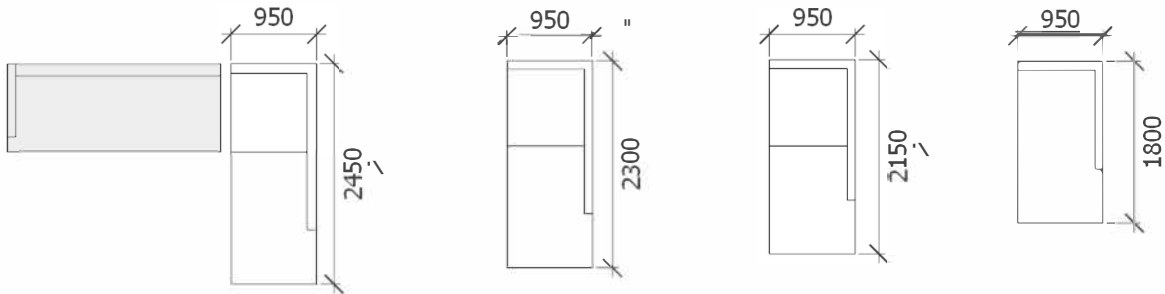

Angular modular components:

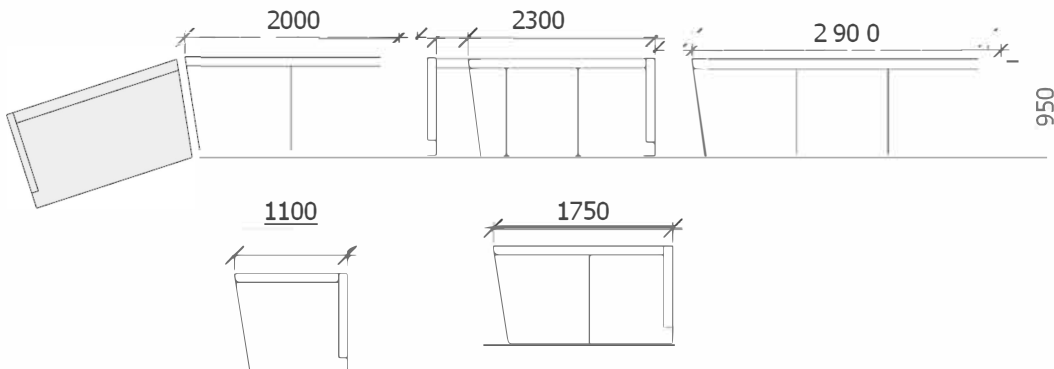

*custom sizes available

*Please note that dimensions are approximate.